

- 1 GPON port
- Gigabit router
- FXS port for analogue phone connection
- USB 2.0 port for USB drive or printer connection
- RF port for CaTV service providing
- Wi-Fi 802.11a/b/g/n/ac

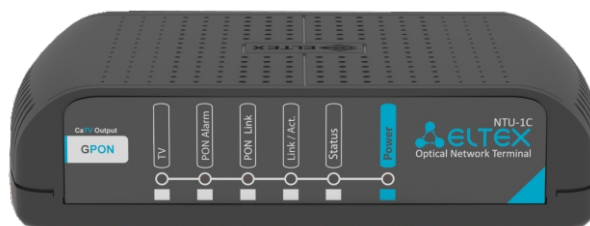

NTU-1C

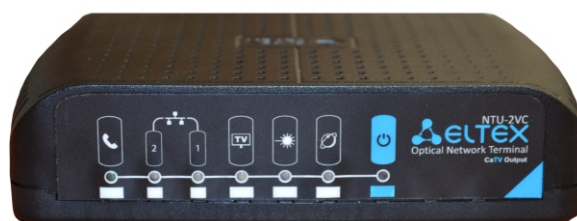

NTU-2VC



NTU-RG-1421GC-Wac

NTU series ONT – high performance multifunctional subscriber terminals that are designed to access modern telephony, IPTV, OTT services as well as high-speed Internet. Furthermore, NTU-RG terminals allow carriers to offer their clients a wide range of services and opportunities to work in a local network.

PON technology

PON technology - one of the most effective last mile solutions today. The technology helps to reduce costs for cable infrastructure and ensures data rates of 2.5 Gbps downlink and 1.25 Gbps uplink. The use of PON technology in access networks allows providing end users with access to IP services.

Universal device

The integrated gigabit router for 4¹ ports of 10/100/1000Base-T ensures high-speed connection of devices in a network. The FXS port provides access to IP telephony services. The USB port can be used for USB device connection (USB flash drive, external HDD, printer).

Provided services

- High-speed access to the Internet
- Stream video/High Definition TV/IPTV, Video on Demand (VoD), video conference
- VoIP
- Online educational and entertainment programmes

Application

- Providing broadband access services to subscribers in apartment houses, residential areas, campuses or suburban settlements
- Corporate network construction at large strategic enterprises or in office buildings with high requirement in terms of security and data transfer rates

Wireless connection

NTU-RG-1421GC-Wac supports IEEE 802.11ac standard, that provides data rates up to 1300 Mbps and delivers modern high performance services to client equipment through the wireless network. Two integrated Wi-Fi controllers ensure simultaneous dual band operation: on 2.4 GHz and 5 GHz.

ONT NTU interfaces configuration

	WAN	LAN	FXS	RF	Wi-Fi	USB
NTU-1C	1xGPON	1x1G	—	1	—	—
NTU-2VC	1xGPON	1x100M + 1x1G	1	1	—	—
NTU-RG-1421GC-Wac	1xGPON	4x1G	1	1	802.11n, 2*2 -300Mbps - 2.4GHz 802.11ac, 3*3 -1.3Gbps - 5 GHz	1 x USB2.0

¹ NTU-1C and NTU-2VC devices have 1 and 2 ports respectively

Features and capabilities

PON interface parameters

- 1 GPON port
- Compliance with ITU-T G.984.2, ITU-T G.984.5 Filter, FSAN Class B+, SFF-8472
- Connector type - SC/APC
- Transmission media - fiber-optic cable SMF - 9/125, G.652
- Maximum operating distance - 20 km
- Transmitter:
 - 1310 nm DFB Upstream Burst Mode Transmitter
 - Data rate: 1244 Mbps
 - Average Launch Power: +0.5..+5 dBm
 - Spectral Line Width 1 nm (-20 dB)
- Receiver:
 - 1490 nm APD/TIA Downstream CW Mode Digital Receiver
 - Data rates: 2488 Mbps
 - Receiver Sensitivity -28 dBm, BER≤1.0x10⁻¹⁰
 - Receiver Optical Overload -4 dBm

CaTV receiver

- CATV video receiver, wavelength 1550 nm
- Input optical power: -8..+2 dBm
- Carrier-to-Noise Ratio (CNR): 46 dB
- RF bandwidth: from 47 to 870 MHz
- HF output: 17 dBmV per channel, with 4 dB positive antenna tilt
- RF output impedance: 75 Ω

LAN interfaces parameters

- 1 port of Ethernet 10/100/1000 Base-T(RJ-45) (NTU-1C)
- 1 port of Ethernet 10/100/1000 Base-T(RJ-45) (NTU-2VC)
- 1 port of Ethernet 10/100 Base-T(RJ-45) (NTU-2VC)
- 4 ports of Ethernet 10/100/1000 Base-T (RJ-45) (NTU-RG-1421GC-Wac)

FXS interfaces parameters

- 1 FXS port
- SIP
- Audio codecs: G.729 (A), G.711(A/U), G.723.1
- Fax transmission: G.711, T.38
- Loop resistance up to 2 kΩ
- Supported dialing technologies: pulse and frequency (DTMF)
- Caller ID issuing

Wi-Fi parameters

NTU-RG-1421GC-Wac

- Supported standards: IEEE 802.11 a/b/g/n/ac
- Frequency range: 2400 ~ 2483.5 MHz, 5150 ~ 5350 MHz, 5650 ~ 5850 MHz
- Simultaneous Dual Band
- Modulations: CCK, BPSK, QPSK, 16 QAM, 64 QAM, 256 QAM

Channels

- 802.11b/g/n: 1-13
- 802.11a/n/ac: 36-64, 132-165

Data rates¹

- 802.11b: 1; 2; 5,5 и 11 Mbps
- 802.11g: 6, 9, 12, 18, 24, 36, 48 and 54 Mbps
- 802.11n: 300 Mbps (20 MHz channel), 450 Mbps (40 MHz channel)³
- 802.11ac: 1300 Mbps (80 MHz)

Maximum output power of the transmitter²

- 802.11b (11 Mbps): 17 dBm
- 802.11g (54 Mbps): 15 dBm
- 802.11n (MCS7): 15 dBm
- 802.11ac (MCS0): 19 dBm

USB interface

NTU-RG-1421GC-Wac

- 1 USB 2.0 port - for USB device connection

Physical parameters and environment conditions

- Dimensions - 160x120x40 mm, desktop case (NTU-1C, NTU-2VC)
- Dimensions - 220x120x50 mm, desktop case (NTU-RG-1421GC-Wac)
- Power supply: external DC adapter 12V/2A
- Maximum power consumption:
 - 5W (NTU-1C)
 - 6W (NTU-2VC)
 - 15W (NTU-RG-1421GC-Wac)
- Operating temperature from +5 to +40°C
- Operating humidity ≤ 80%

Supported standards

- ITU-T G.984.x - GPON
- ITU-T G.988 OMCI specification
- IEEE 802.1D
- IEEE 802.1Q
- IEEE 802.1P

Specifications

- Support for TR-069
- “Bridge” and “Router” (including virtual ones) operation modes
- Support for PPPoE (auto, PAP, MSCHAP and CHAP authentication)
- Support for IPoE (DHCP client and static)
- DHCP server on LAN side
- Multicast traffic transmission via Wi-Fi
- DNS (Domain Name System)
- DynDNS (Dynamic DNS)
- UPNP (Universal Plug and Play)
- NAT (Network Address Translation)
- NTP (Network Time Protocol)
- Quality of Service (QoS)
- IGMP Snooping
- IGMP Proxy
- Support for UPNP, SMB, FTP-alg, Print Server
- VLAN complying with IEEE 802.1Q

¹The maximum wireless data rate is defined according to IEEE 802.11n/ac standard. The real bandwidth can be different. Conditions of the network operation, environment, the amount of traffic, building materials and constructions as well as network service data can decrease the real bandwidth. The environment can influence on the network coverage range.

²The value of the maximum output power will vary according to the rules of radio frequency regulation in your country.

Features and capabilities (continuation)

Security functions

- Rate limiting per ports
- FEC coding

Configuration and monitoring

- According to TR-142:
 - Remote management via OMCI
 - Remote management via TR-069
- Local management via WEB/CLI
- Firmware updating via: OMCI, TR-069, HTTP, TFTP

Use Case

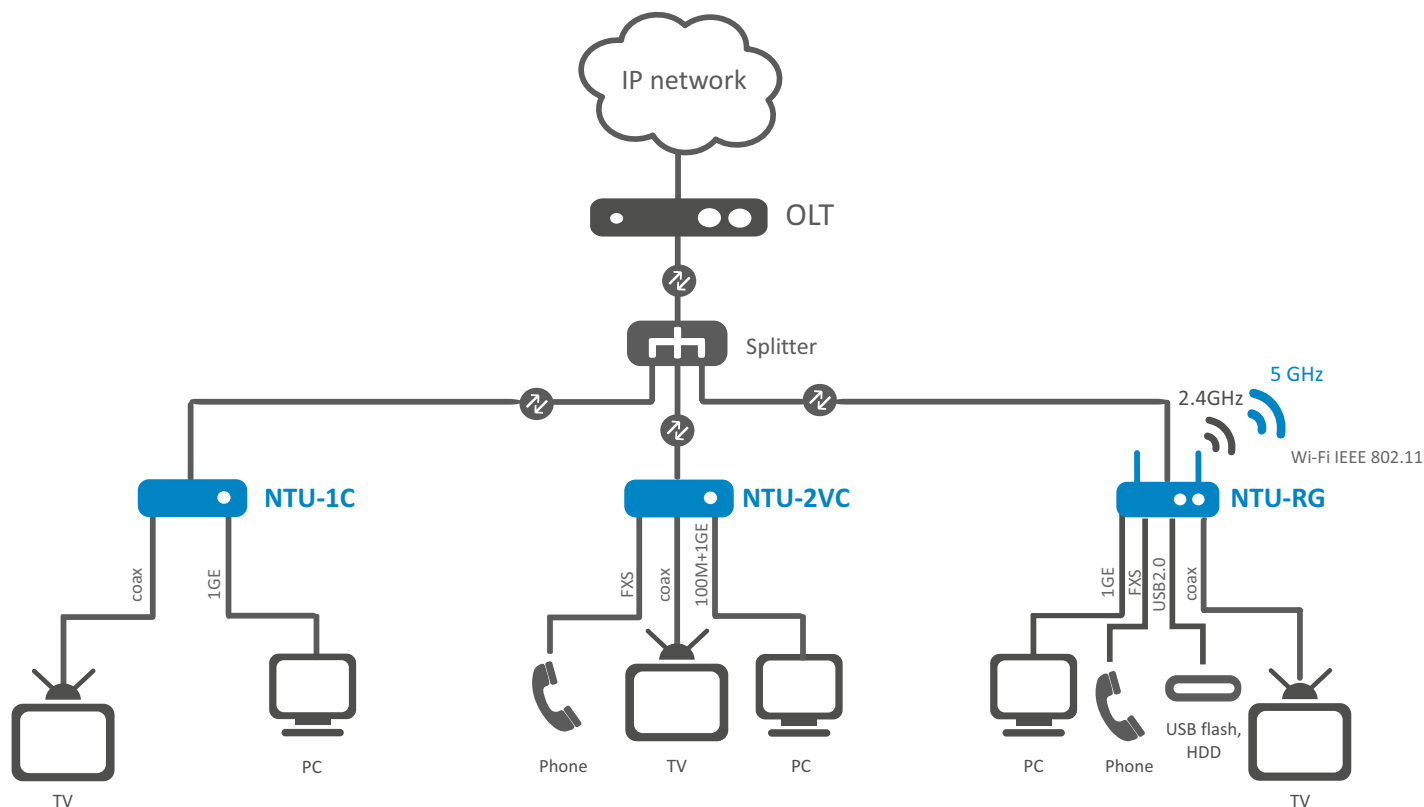

Name	Description	Image
NTU-1C	ONT NTU-1C, 1 LAN port of 10/100/1000Base-T, 1xRF	
NTU-2VC	ONT NTU-2VC, 1 LAN port of 10/100/1000Base-T, 1 LAN port of 10/100Base-T, 1xFXS, 1xRF	
NTU-RG-1421GC-Wac	ONT NTU-RG-1421GC-Wac, 4 LAN ports of 10/100/1000Base-T, 1xUSB, 1xFXS, 1xRF, WiFi (802.11n, 2*2 -300Mbps - 2.4GHz +802.11ac, 3*3 - 1.3Gbps-5 GHz)	

Related Software

ACS-CPE-512

ACS-CPE-512 option of Eltex.ACS system for Eltex CPE autoconfiguration: 512 subscriber devices

ACS-CPE-1024

ACS-CPE-1024 option of Eltex.ACS system for Eltex CPE autoconfiguration: 1024 subscriber devices

Contact us

+7 (383) 274 10 01
+7 (383) 274 48 48

eltex@eltex-co.ru

www.eltex-co.ru

About Eltex

Eltex company is a leading Russian developer and manufacturer of telecommunication equipment with 25 years of history. Integrity of solutions and seamless integration capability into Customer infrastructure is a priority area of company development.